

Serie T: [TiM]

DESIGN MATTEO THUN & ANTONIO RODRIGUEZ

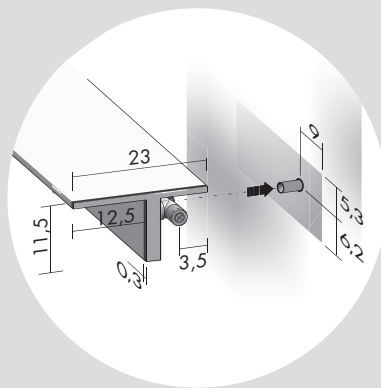

Minimum distance per side recommended for installation: 10 cm
 Distance minimale conseillée pour chaque côté pour l'installation: 10 cm
 Der für den Einbau empfohlene Mindestseitenabstand beträgt: 10 cm
 Distancia mínima por lado aconsejada para la instalación: 10 cm

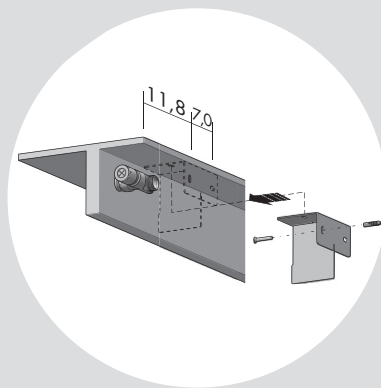
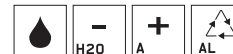

TiM | ≥ 10 cm | ≥ 10 cm |

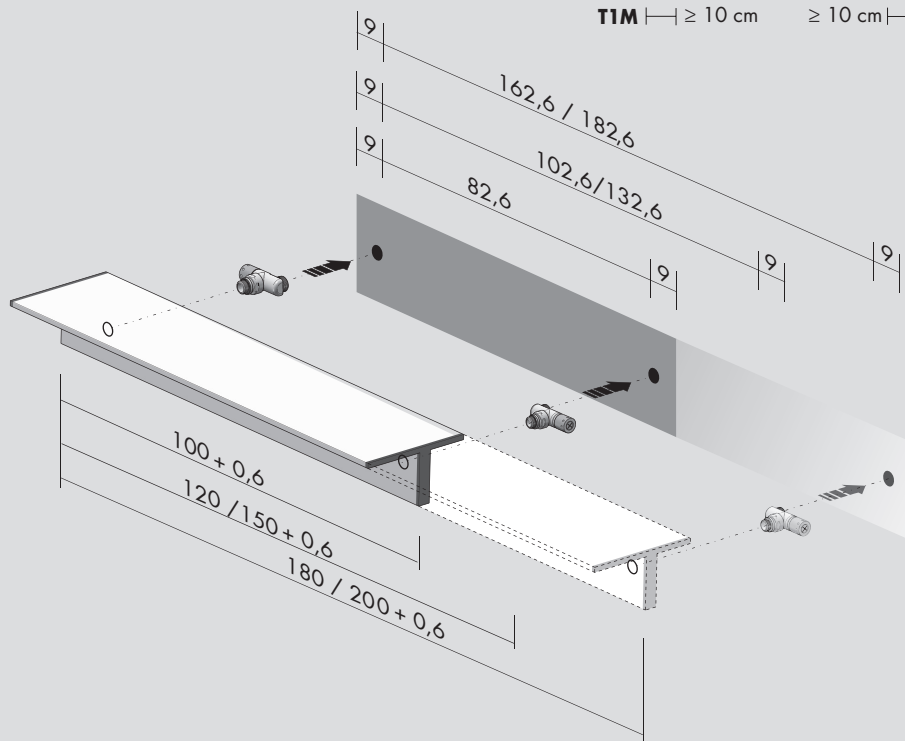

Tailoring / Sur mesure / Nach maß / A medida

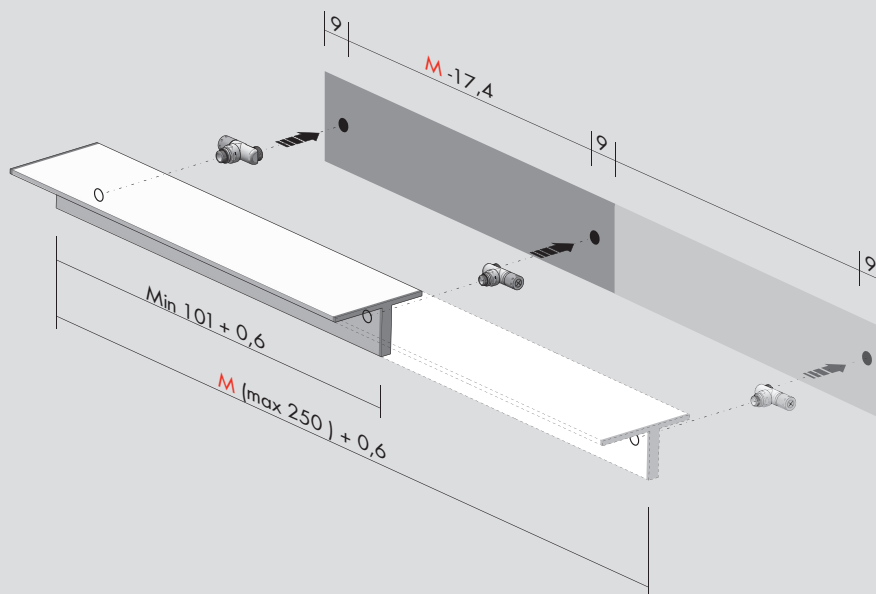

Kcal = Watt x 0.860
 BTU = Watt x 3.413

Watt Δt 60° = Watt Δt 50° x 1.245
 Watt Δt 40° = Watt Δt 50° x 0.765
 Watt Δt 30° = Watt Δt 50° x 0.541
 Watt Δt 20° = Watt Δt 50° x 0.332

p max = 6.5 bar

Serie T : [TIM]

H cm	L cm	I* cm	art*	Lt*	watt Δt 30°	watt Δt 50°
11.5	100.6	82.6	T1M100001_	0.3	138	256
11.5	120.6	102.6	T1M120001_	0.3	166	307
11.5	150.6	132.6	T1M150001_	0.4	208	384
11.5	180.6	162.6	T1M180001_	0.5	248	461
11.5	200.6	182.6	T1M200001_	0.6	277	512

Tailoring / Sur mesure / Nach maß / A medida

	art*	watt/cm Δt 30°	watt/cm Δt 50°
DA 101 A 119	T1M(M)_	1.38	2.56
DA 121 A 149	T1M(M)_	1.38	2.56
DA 151 A 179	T1M(M)_	1.38	2.56
DA 181 A 199	T1M(M)_	1.38	2.56
DA 201 A 250	T1M(M)_	1.38	2.56

To order a tailored radiator, specify length "M".

Pour commander un radiateur sur mesure, veuillez spécifier la longueur "M".

Bei der Bestellung eines nach Maß angefertigten Heizkörpers die Länge "M" angeben.

Para pedir un radiador a medida especificar la longitud "M".

■ = For information about transport, see page 2 / Voir la page 2 pour transport / die Transportspezifikationen finden Sie auf Seite 2 / Porte: ver página 2

Standard



(P* = 225)

"S" Valve
 Vanne "S"
 "S" Ventil
 Válvula "S"

[BIAN] **E38SB**
 [CROM] **E38SR**

Optional



(P* = 226)

Thermostatic head
 Tête thermostatique
 Thermostatkopf
 Cabezal termostático

[BIAN] **TTB**
 [CROM] **TTR**

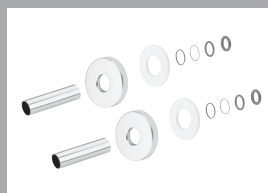

$\varnothing \leq 16$ mm

[BIAN] **CTB**
 [CROM] **CTR**

16 mm $< \varnothing < 24$ mm

[BIAN] **CWB**
 [CROM] **CWR**

art* = item / modèle / Artikel / artículo I* = pipe centres / distance entre depart et retour / Achsabstand / distancia entre las conexiones

Lt* = water content for each element / volume d'eau pour chaque element / Wassergehalt für Element / contenido de agua por cada elemento

P* = page / page / Seite / página

Serie T: [TiP]

DESIGN MATTEO THUN & ANTONIO RODRIGUEZ

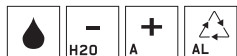
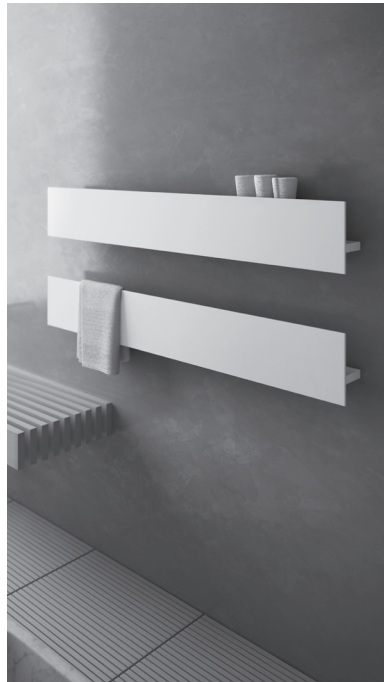

Kcal = Watt x 0.860
BTU = Watt x 3.413

Watt Δt 60° = Watt Δt 50° x 1.245
Watt Δt 40° = Watt Δt 50° x 0.765
Watt Δt 30° = Watt Δt 50° x 0.541
Watt Δt 20° = Watt Δt 50° x 0.332

p max = 6.5 bar

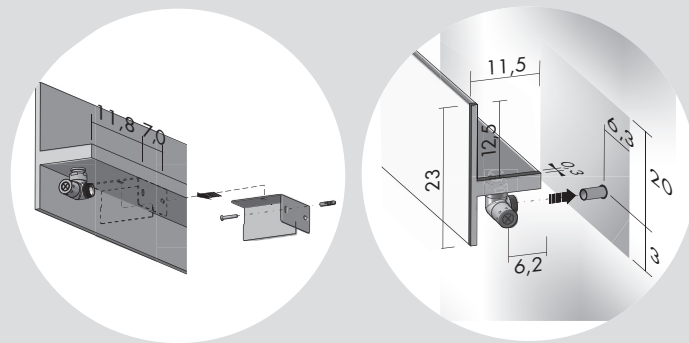

Minimum distance per side recommended for installation: 10 cm
Distance minimale conseillée pour chaque côté pour l'installation: 10 cm
Der für den Einbau empfohlene Mindestseitenabstand beträgt: 10 cm
Distancia mínima por lado aconsejada para la instalación: 10 cm



TiP |—| ≥ 10 cm ≥ 10 cm |—|

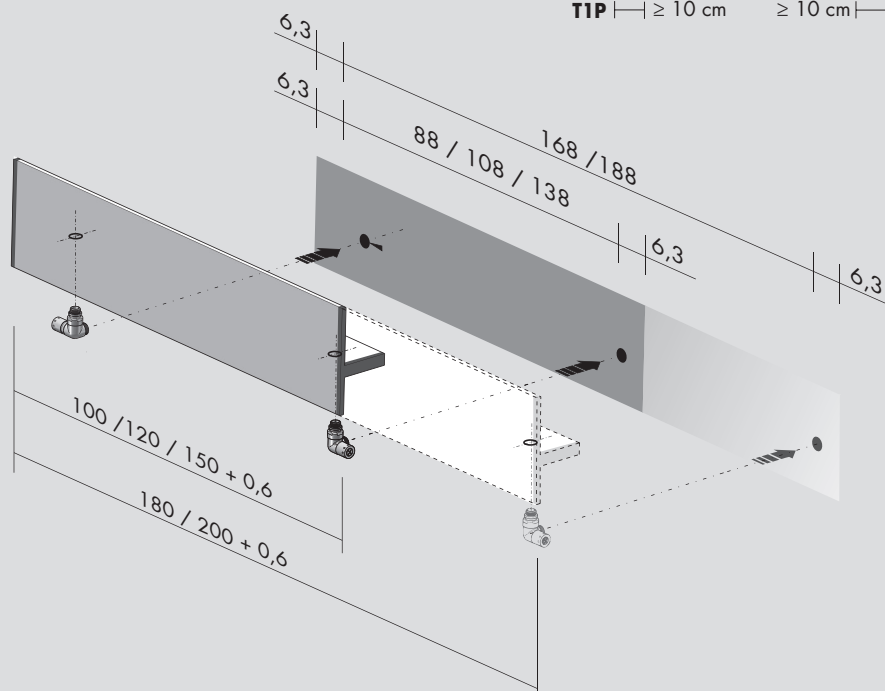

Tailoring / Sur mesure / Nach maß / A medida

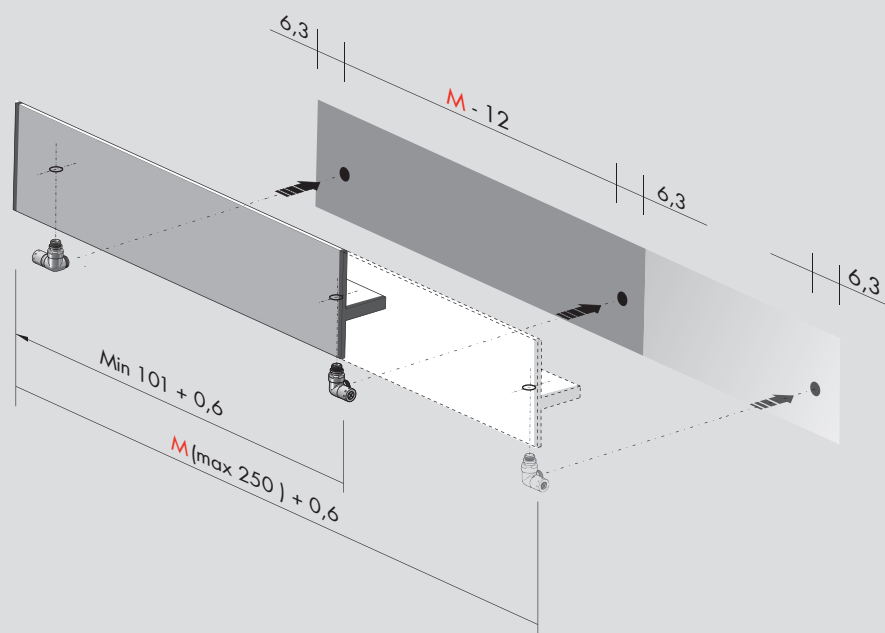

Serie T : [T1P]

H cm	L cm	l* cm	art*	lt*	watt Δt 30°	watt Δt 50°
23.0	100.6	88.0	T1P100001_	0.3	138	256
23.0	120.6	108.0	T1P120001_	0.3	166	307
23.0	150.6	138.0	T1P150001_	0.4	208	384
23.0	180.6	168.0	T1P180001_	0.5	248	461
23.0	200.6	188.0	T1P200001_	0.6	277	512

Tailoring / Sur mesure / Nach maß / A medida

	art*	watt/cm Δt 30°	watt/cm Δt 50°
DA 101 A 119	T1P(M)_	1.38	2.56
DA 121 A 149	T1P(M)_	1.38	2.56
DA 151 A 179	T1P(M)_	1.38	2.56
DA 181 A 199	T1P(M)_	1.38	2.56
DA 201 A 250	T1P(M)_	1.38	2.56

To order a tailored radiator, specify length "M".

Pour commander un radiateur sur mesure, veuillez spécifier la longueur "M".

Bei der Bestellung eines nach Maß angefertigten Heizkörpers die Länge "M" angeben.

Para pedir un radiador a medida especificar la longitud "M".

■ = For information about transport, see page 2 / Voir la page 2 pour transport / die Transportspezifikationen finden Sie auf Seite 2 / Porte: ver página 2

Optional

Towel rail slot / Fente porte-serviette / Spalt Handtuchhalter / Ranura toallero

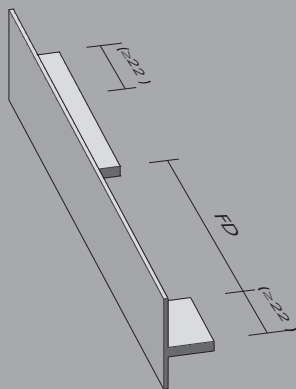

FD standard (56 cm)
FDX ≈ 56 cm

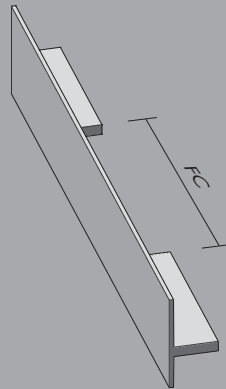

FC standard (56 cm)
FCX ≈ 56 cm

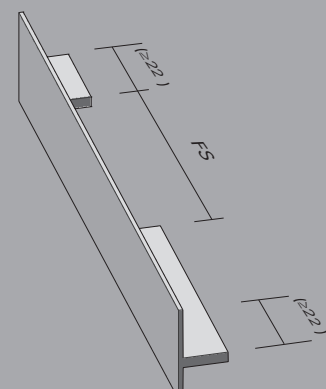

FS standard (56 cm)
FSX ≈ 56 cm

Standard



"Corner" Valve
 Vanne "Corner"
 "Corner" Ventil
 Válvula "Corner"

[BIAN] **E38CRB**
 [CROM] **E38CRR**



Thermostatic head
 Tête thermostatique
 Thermostatkopf
 Cabezal termostático

[BIAN] **TTB**
 [CROM] **TTR**

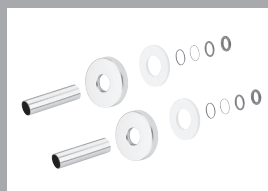

$\varnothing \leq 16$ mm
 [BIAN] **CTB**
 [CROM] **CTR**

$16 \text{ mm} < \varnothing < 24$ mm
 [BIAN] **CWB**
 [CROM] **CWR**

art* = item / modèle / Artikel / artículo l* = pipe centres / distance entre depart et retour / Achsabstand / distancia entre las conexiones
 Lt* = water content for each element / volume d'eau pour chaque element / Wassergehalt für Element / contenido de agua por cada elemento
 P* = page / page / Seite / página

Serie T: [T2O]

DESIGN MATTEO THUN & ANTONIO RODRIGUEZ

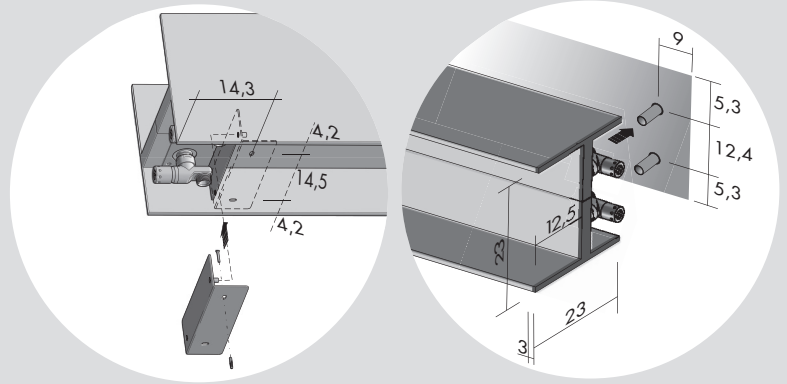
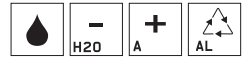

Minimum distance per side recommended for installation: 20 cm
 Distance minimale conseillée pour chaque côté pour l'installation: 20 cm
 Der für den Einbau empfohlene Mindestseitenabstand beträgt: 20 cm
 Distancia mínima por lado aconsejada para la instalación: 20 cm



T20 |—| ≥ 20 cm ≥ 20 cm |—|

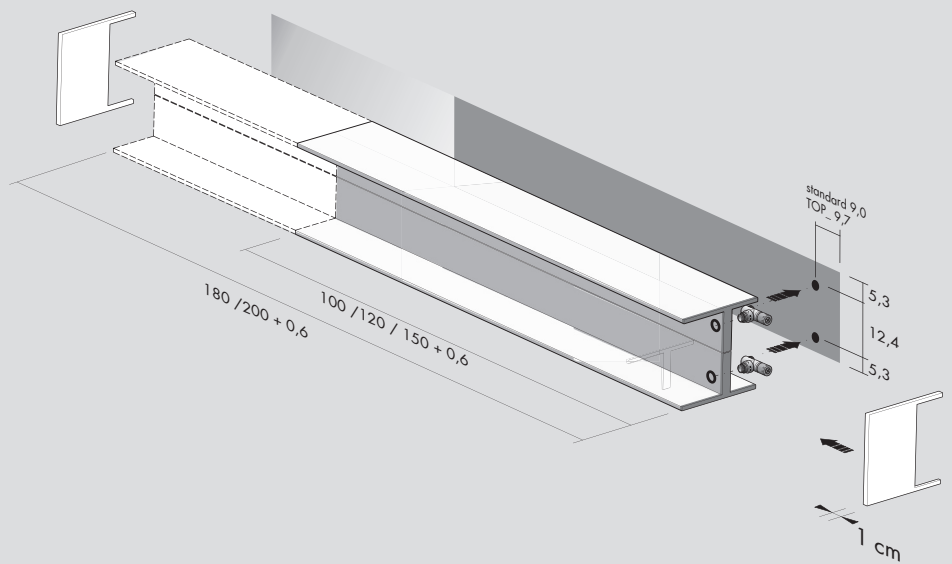

Tailoring / Sur mesure / Nach maß / A medida

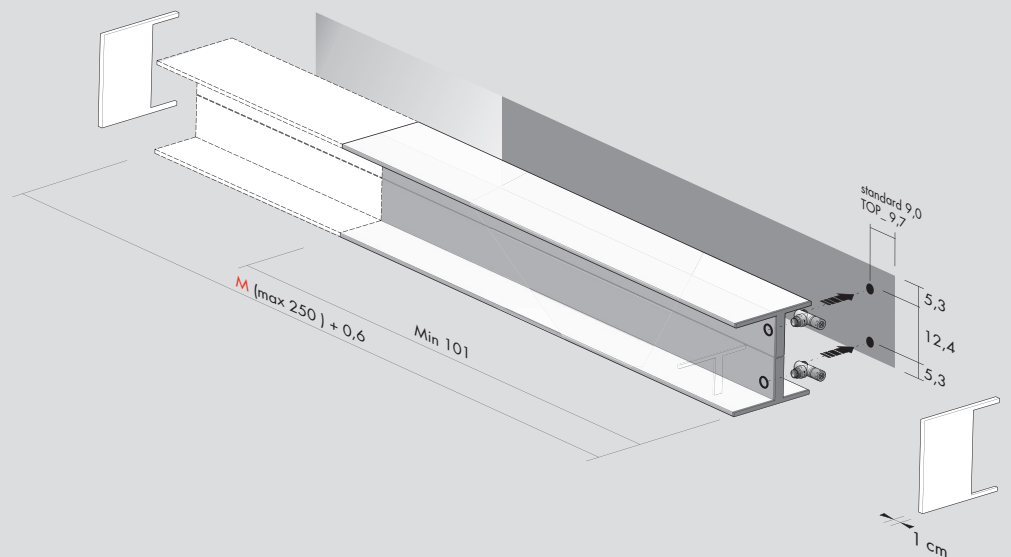

Kcal = Watt x 0.860
 BTU = Watt x 3.413

Watt Δt 60° = Watt Δt 50° x 1.245
 Watt Δt 40° = Watt Δt 50° x 0.765
 Watt Δt 30° = Watt Δt 50° x 0.541
 Watt Δt 20° = Watt Δt 50° x 0.332

p max = 4.0 bar

Serie T : [T2O]

H cm	L cm	I* cm	art*	Lt*	watt Δt 30°	watt Δt 50°
23.0	100.6	12.4	T2O100002_	0.5	276	512
23.0	120.6	12.4	T2O120002_	0.7	332	614
23.0	150.6	12.4	T2O150002_	0.9	415	768
23.0	180.6	12.4	T2O180002_	1.0	497	922
23.0	200.6	12.4	T2O200002_	1.1	554	1 024

Tailoring / Sur mesure / Nach maß / A medida

	art*	watt/cm Δt 30°	watt/cm Δt 50°
DA 101 A 119	T2O(M)_	2.76	5.12
DA 121 A 149	T2O(M)_	2.76	5.12
DA 151 A 179	T2O(M)_	2.76	5.12
DA 181 A 199	T2O(M)_	2.76	5.12
DA 201 A 250	T2O(M)_	2.76	5.12

To order a tailored radiator, specify length "M".

Pour commander un radiateur sur mesure, veuillez spécifier la longueur "M".

Bei der Bestellung eines nach Maß angefertigten Heizkörpers die Länge "M" angeben.

Para pedir un radiador a medida especificar la longitud "M".

■ = For information about transport, see page 2 / Voir la page 2 pour transport / die Transportspezifikationen finden Sie auf Seite 2 / Porte: ver página 2

Standard



(P* = 225)

"S" Valve
 Vanne "S"
 "S" Ventil
 Válvula "S"

[BIAN] **E38SB**
 [CROM] **E38SR**

Optional



(P* = 226)

Thermostatic head
 Tête thermostatique
 Thermostatkopf
 Cabezal termostático

[BIAN] **TTB**
 [CROM] **TTR**

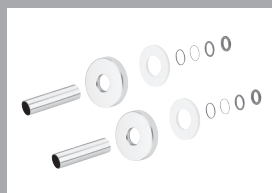

$\varnothing \leq 16$ mm
 [BIAN] **CTB**
 [CROM] **CTR**

$16 \text{ mm} < \varnothing < 24$ mm
 [BIAN] **CWB**
 [CROM] **CWR**

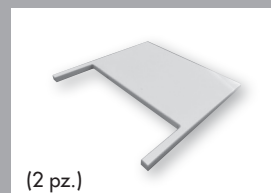

(2 pz.)

Optional terminal (2)
 Terminal en option (2)
 Optionaler Endheizkörper (2)
 Terminal Optional (2)

[B] **TOPB**
 [T] **TOPT**
 [S] **TOPS**

art* = item / modèle / Artikel / artículo **I*** = pipe centres / distance entre depart et retour / Achsabstand / distancia entre las conexiones
Lt* = water content for each element / volume d'eau pour chaque element / Wassergehalt für Element / contenido de agua por cada elemento
P* = page / page / Seite / página

Serie T: [T2V]

DESIGN MATTEO THUN & ANTONIO RODRIGUEZ

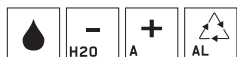

Kcal = Watt x 0.860
BTU = Watt x 3.413

Watt Δt 60° = Watt Δt 50° x 1.259
Watt Δt 40° = Watt Δt 50° x 0.754
Watt Δt 30° = Watt Δt 50° x 0.524
Watt Δt 20° = Watt Δt 50° x 0.314

p max = 4.0 bar

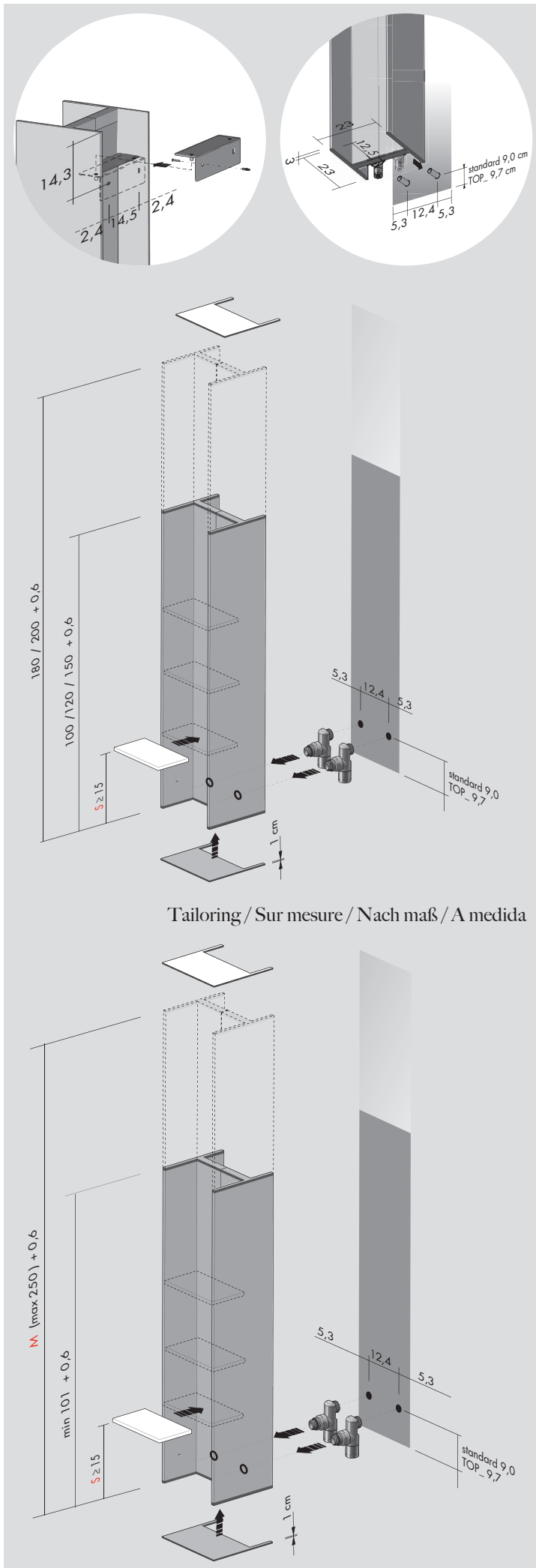

Tailoring / Sur mesure / Nach maß / A medida

Output T2V / Puissance T2V
Heizleistung T2V / Potencia máxima T2V

H cm	watt Δt 50°	H cm	watt Δt 50°
100	512	181	876
101	517	182	881
102	521	183	885
103	526	184	890
104	530	185	894
105	535	186	899
106	539	187	903
107	544	188	908
108	549	189	912
109	553	190	917
110	558	191	921
111	562	192	925
112	567	193	930
113	571	194	934
114	576	195	939
115	580	196	943
116	585	197	948
117	589	198	952
118	594	199	957
121	608	200	961
122	612	201	966
123	617	202	970
124	621	203	974
125	626	204	979
126	630	205	983
127	635	206	988
128	639	207	992
129	644	208	997
130	648	209	1 001
131	653	210	1 006
132	657	211	1 010
133	662	212	1 014
134	666	213	1 019
135	671	214	1 023
136	675	215	1 028
137	680	216	1 032
138	684	217	1 037
139	689	218	1 041
140	693	219	1 046
141	698	220	1 050
142	702	221	1 055
143	707	222	1 059
144	711	223	1 063
145	716	224	1 068
146	720	225	1 072
147	725	226	1 077
148	729	227	1 081
149	734	228	1 086
150	738	229	1 090
151	742	230	1 095
152	747	231	1 099
153	751	232	1 104
154	756	233	1 108
155	760	234	1 112
156	765	235	1 117
157	769	236	1 121
158	774	237	1 126
159	778	238	1 130
160	783	239	1 135
161	787	240	1 139
162	792	241	1 144
163	796	242	1 148
164	801	243	1 153
165	805	244	1 157
166	810	245	1 162
167	814	246	1 166
168	818	247	1 170
169	823	248	1 175
170	827	249	1 179
171	832	250	1 184
172	836		
173	841		
174	845		
175	850		
176	854		
177	859		
178	863		
179	868		
180	872		

Serie T : [T2V]

H cm	L cm	I* cm	art*	Li*	watt Δt 30°	watt Δt 50°
100.6	23.0	12.4	T2V100002_	0.5	268	512
120.6	23.0	12.4	T2V120002_	0.7	316	603
150.6	23.0	12.4	T2V150002_	0.9	387	738
180.6	23.0	12.4	T2V180002_	1.0	457	872
200.6	23.0	12.4	T2V200002_	1.1	504	961

Tailoring / Sur mesure / Nach maß / A medida

	art*	watt/cm Δt 50°
DA 101 A 119	T2V(M)_	P* 60
DA 121 A 149	T2V(M)_	P* 60
DA 151 A 179	T2V(M)_	P* 60
DA 181 A 199	T2V(M)_	P* 60
DA 201 A 250	T2V(M)_	P* 60

To order a tailored radiator, specify length "M".

Pour commander un radiateur sur mesure, veuillez spécifier la longueur "M".

Bei der Bestellung eines nach Maß angefertigten Heizkörpers die Länge "M" angeben.

Para pedir un radiador a medida especificar la longitud "M".

To order shelves, specify the number of shelves (N) and the distance between them (S). The centre distance must be even and "greater than or equal to" 15 cm from the base.

Pour commander les étagères, veuillez spécifier le numéro d'étagères (N) et l'écartement entre les étagères (S) qui devra être régulier et «supérieur ou égal» à 15 cm en partant du bas.

Bei der Bestellung der Regale bitte die Anzahl der Regale (N) und den Abstand (S) zwischen denselben anführen; dieser muss einheitlich sein und, von unten ausgehend, mindestens 15 cm betragen.

Para pedir las repisas especificar el número de repisas (N) y la distancia entre ellas (S), que tendrá que ser regular y "mayor o igual" a 15 cm desde abajo.

A chrome bathrobe hook is available for the T2V version. This hook can be ordered as an accessory following installation of the radiator. For the version with optional terminals (TOP_) the bathrobe holder must be ordered together with the radiator.

Dans la version T2V, il existe un crochet porte-peignoir chromé qui peut être commandé en tant qu'accessoire, même après l'installation du radiateur. Dans les versions où les terminaux sont en option (TOP_), le crochet porte-peignoir doit être commandé en même temps que le radiateur.

In der Version T2V ist ein verchromter Bademantelhaken erhältlich, der als Zubehör auch nach dem Einbau des Heizkörpers bestellt werden kann. In der Version mit den optionalen Endheizkörpern (TOP_) muss der Bademantelhaken zusammen mit dem Heizkörper bestellt werden.

En la versión T2V se encuentra disponible un gancho perchero para albornoces cromado, que se puede pedir como accesorio incluso sucesivamente a la instalación del radiador. En las versiones con los terminales opcionales (TOP_), el gancho perchero para albornoces se tiene que pedir de forma contemporánea con el radiador.

■ = For information about transport, see page 2 / Voir la page 2 pour transport / die Transportspezifikationen finden Sie auf Seite 2 / Porte: ver página 2

Standard



(P* = 225)

"S" Valve
 Vanne "S"
 "S" Ventil
 Válvula "S"

[BIAN] **E38SB**
 [CROM] **E38SR**

Optional



(P* = 226)

Thermostatic head
 Tête thermostatique
 Thermostatkopf
 Cabezal termostático

[BIAN] **TTB**
 [CROM] **TTR**

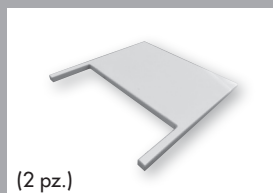

(2 pz.)

Optional terminal
 Terminal en option
 Optionaler Endheizkörper
 Terminal Optional

[B] **TOPB**
 [T] **TOPT**
 [S] **TOPS**

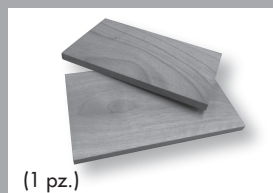

(1 pz.)

Shelves with a walnut finish
 Étagères en bois finition noyer
 Regale aus nussholz verfügbar
 Repisas de madera con acabado nogal

[WOOD] **TW**



Towel hooks
 Patère
 Crochet das Bugel
 Percha

[CROM] **ASTR**
 [COLOUR] **ASTC**
 [GOLD] **ASTG**

art* = item / modèle / Artikel / artículo I* = pipe centres / distance entre départ et retour / Achsabstand / distancia entre las conexiones

Li* = water content for each element / volume d'eau pour chaque element / Wassergehalt für Element / contenido de agua por cada elemento

P* = page / page / Seite / página