

1. LAMBREQUINS

1.1 Types de lambrequins

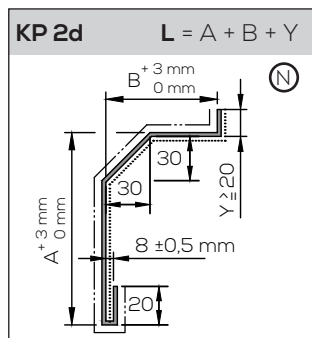
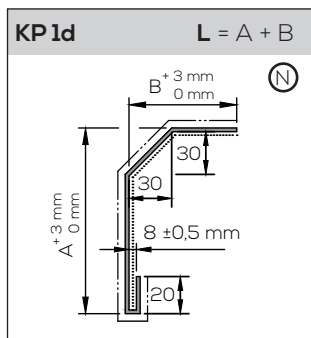
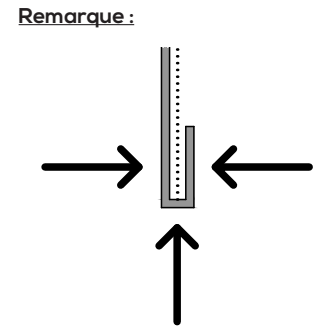
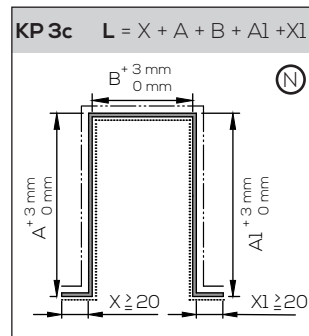
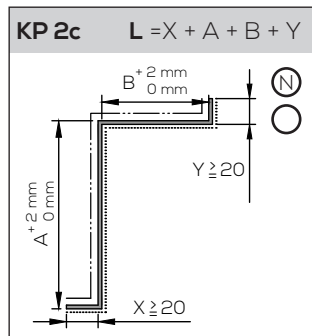
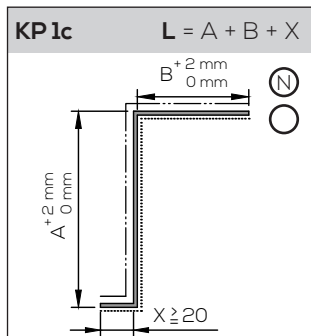
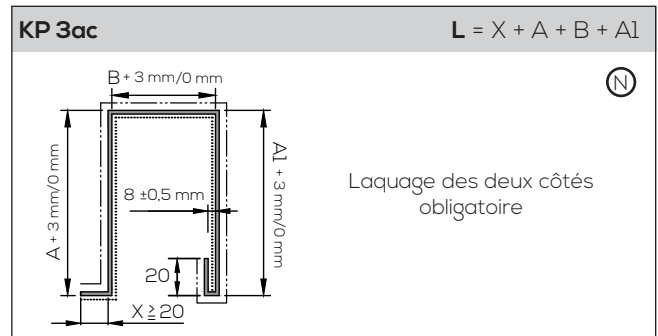
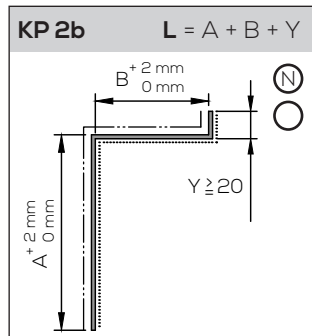
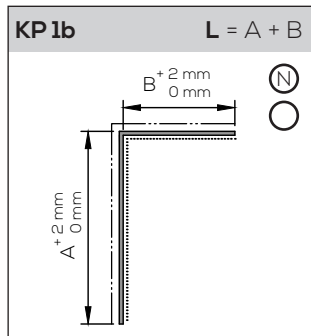
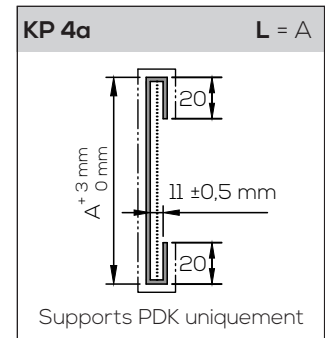
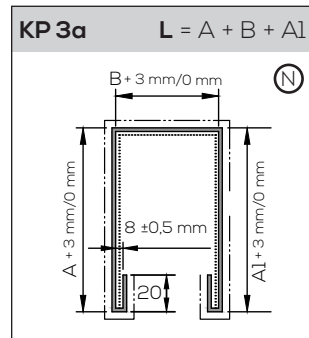
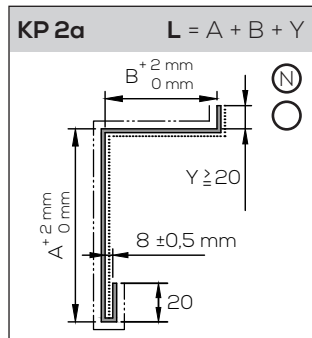
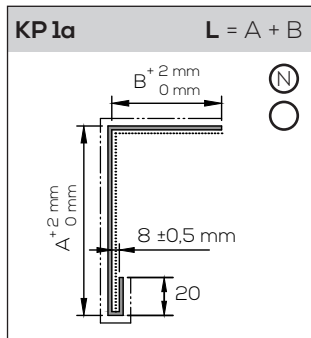

Légende :

- (N) = Joes latérales rivetées ou livrées séparées
- (O) = Joes latérales pliées
- L = Développé total
- Parties extérieures laquées
- Parties intérieures laquées

