

Tie rod cylinder ISO 15552, Series TRB

- ISO 15552
- Ø 32-125 mm
- Ports G 1/8 G 1/4 G 3/8 G 1/2
- double-acting
- with magnetic piston
- Cushioning pneumatically adjustable
- Piston rod External thread
- Piston rod through
- ATEX optional

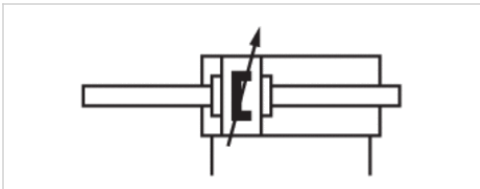

Standards	ISO 15552
Compressed air connection	Internal thread
Working pressure min./max.	1,5 ... 10 bar
Ambient temperature min./max.	-20 ... 80 °C
Medium temperature min./max.	-20 ... 80 °C
Medium	Compressed air
Max. particle size	50 µm
Oil content of compressed air	0 ... 5 mg/m ³
Pressure for determining piston forces	6.3 bar

Technical data

Piston Ø Piston rod thread Ports Piston rod Ø	32 mm M10x1,25 G 1/8 12 mm	40 mm M12x1,25 G 1/4 16 mm	50 mm M16x1,5 G 1/4 20 mm	63 mm M16x1,5 G 3/8 20 mm	80 mm M20x1,5 G 3/8 25 mm	100 mm M20x1,5 G 1/2 25 mm
Stroke 25	0822340501	0822341501	0822342501	0822343501	0822344501	0822345501
50	0822340502	0822341502	0822342502	0822343502	0822344502	0822345502
80	0822340503	0822341503	0822342503	0822343503	0822344503	0822345503
100	0822340504	0822341504	0822342504	0822343504	0822344504	0822345504
125	0822340505	0822341505	0822342505	0822343505	0822344505	0822345505
160	0822340506	0822341506	0822342506	0822343506	0822344506	0822345506
200	0822340507	0822341507	0822342507	0822343507	0822344507	0822345507
250	0822340508	0822341508	0822342508	0822343508	0822344508	0822345508
320	0822340509	0822341509	0822342509	0822343509	0822344509	0822345509
400	0822340510	0822341510	0822342510	0822343510	0822344510	0822345510
500	0822340511	0822341511	0822342511	0822343511	0822344511	0822345511

Piston Ø Piston rod thread Ports Piston rod Ø	125 mm M27x2 G 1/2 32 mm
Stroke 25	R480166022
50	7472410919
80	7472024294
100	7472412262
125	7472412263
160	7472412264
200	7472412265
250	7472412266
320	7472412267
400	7472412268
500	7472412269

Technical data

Piston Ø	32 mm	40 mm	50 mm	63 mm
Retracting piston force	435 N	660 N	1035 N	1765 N
Extracting piston force	435 N	660 N	1035 N	1765 N
Cushioning length	16,5 mm	19 mm	17 mm	16,5 mm
Cushioning energy	4,8 J	9 J	15 J	27 J
Weight 0 mm stroke	0,52 kg	0,82 kg	1,42 kg	1,7 kg
Weight +10 mm stroke	0,033 kg	0,046 kg	0,061 kg	0,077 kg
Tie-rods	Stainless steel	Stainless steel	Steel galvanized	Steel galvanized
Stroke max.	1500 mm	1500 mm	1500 mm	1500 mm

Piston Ø	80 mm	100 mm	125 mm
Retracting piston force	2855 N	4635 N	7220 N
Extracting piston force	2855 N	4635 N	7220 N
Cushioning length	19,5 mm	495,3 mm	22 mm
Cushioning energy	54 J	88 J	140 J
Weight 0 mm stroke	2,67 kg	3,7 kg	9 kg
Weight +10 mm stroke	0,099 kg	0,104 kg	0,26 kg
Tie-rods	Steel galvanized	Steel galvanized	Steel galvanized
Stroke max.	1500 mm	1500 mm	1500 mm

Technical information

The pressure dew point must be at least 15 °C under ambient and medium temperature and may not exceed 3 °C .

The oil content of compressed air must remain constant during the life cycle.

Use only the approved oils from AVENTICS. Further information can be found in the "Technical information" document (available in the MediaCentre).

Technical information

Material	
Cylinder tube	Aluminum, anodized
Piston rod	Stainless steel
Front cover	Die-cast aluminum
End cover	Die-cast aluminum
Seal	Polyurethane
Nut for piston rod	Steel, galvanized
Scraper	Polyurethane
Tie-rods	Stainless steel Steel, galvanized
	See table for additional data on materials.

Dimensions

Dimensions

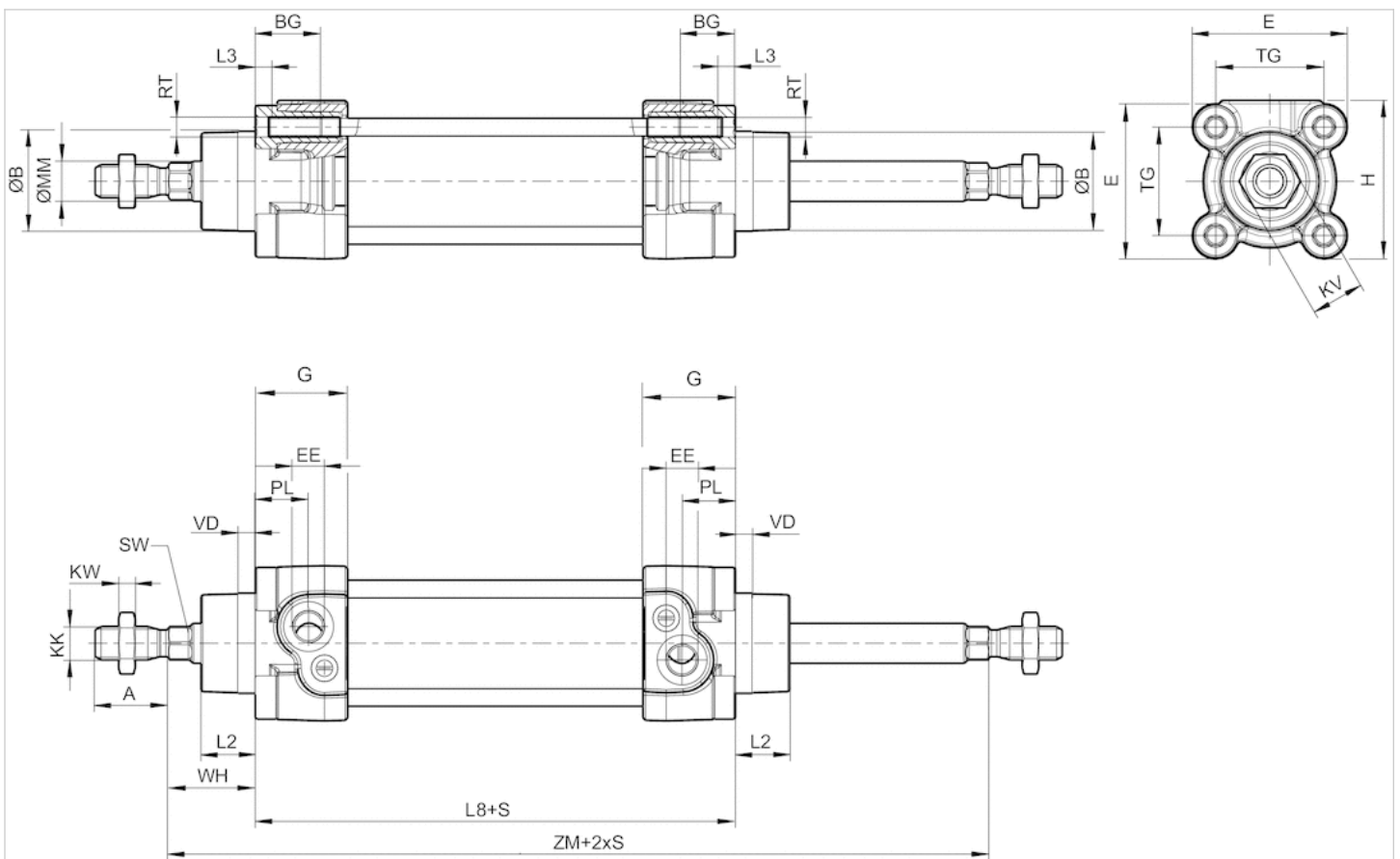

S = stroke

Dimensions

Piston Ø	A -2	ØB d11	BG min.	E	EE	G	H	KK	KV	KW	ØMM f8	PL	L2
32 mm	22	30	16	46.5	G1/8	27.75	47.5	M10x1,25	16	5	12	16	16.25
40 mm	24	35	16	53	G1/4	33.25	53	M12x1,25	18	6	16	20	18.25
50 mm	32	40	16	65	G1/4	31	65	M16x1,5	24	8	20	19	25
63 mm	32	45	16	75	G3/8	38.25	75	M16x1,5	24	8	20	24	25
80 mm	40	45	17	95	G3/8	38.25	95	M20x1,5	30	10	25	23.5	33
100 mm	40	55	17	115	G1/2	42.25	115	M20x1,5	30	10	25	25	36
125 mm	54	60	20	140	G1/2	53.85	140	M27x2	41	13.5	32	33	45

Piston Ø	L3 ±0,5	L8	RT	SW	TG	VD	WH	ZM
32 mm	4.5	94±0,4	M6	10	32,5±0,5	5	26±1,4	146+3/-1,5
40 mm	4.5	105±0,7	M6	13	38±0,5	5	30±1,4	165+3/-1,5
50 mm	4.5	106±0,7	M8	17	46,5±0,6	5	37±1,4	180+3/-1,5
63 mm	4.5	121±0,8	M8	17	56,5±0,7	5	37±1,8	195+3/-1,5
80 mm	0	128±0,8	M10	22	72±0,7	5	46±1,8	220+3/-1,5
100 mm	0	138±1	M10	22	89±0,7	5	51±1,8	240+3,5/-2
125 mm	0	160±1	M12	27	110±1,1	7	65±2,2	290+3,5/-2

Diagrams

Cushioning diagram

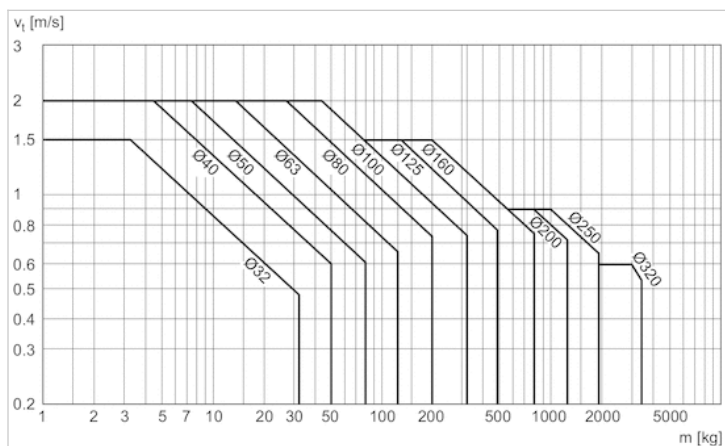

v_i = Piston velocity [m/s]

m = Cushionable mass [kg]

Accessories overview

